

# BASKET TYPE STRAINERS

Type 507.1 - ANSI #150 lb  
Type 507.2 - ANSI #300 lb

Cast body  
Flanged Cover  
Sizes 2" to 14"  
Flanged Ends

For more than twenty years CONACO™ strainers have been considered as the industry standard for the protection of valves, pumps, turbines and any other pipeline equipment requiring a contaminant-free operation.

#### Design:

- Very low pressure drop, due to the generously sized screen.
- An exclusive proprietary software can calculate the pressure drop for any design condition and strainer configuration.
- Cover is fastened with standard nuts or quick release wingnuts, according to customer's requirements.
- O-ring type cover-body sealing.
- No special tooling required for installation and maintenance.
- High basket capacity for heavily contaminated fluids.

#### Available sizes

- From 2" to 14" ANSI #150 lb
- From 2" to 10" ANSI #300 lb

#### Manufacturing:

- Full traceability of all parts of all strainers ever produced.
- All strainers are individually Hydrostatically tested to API 598
- Quality System to ISO 9001
- **CE** marking

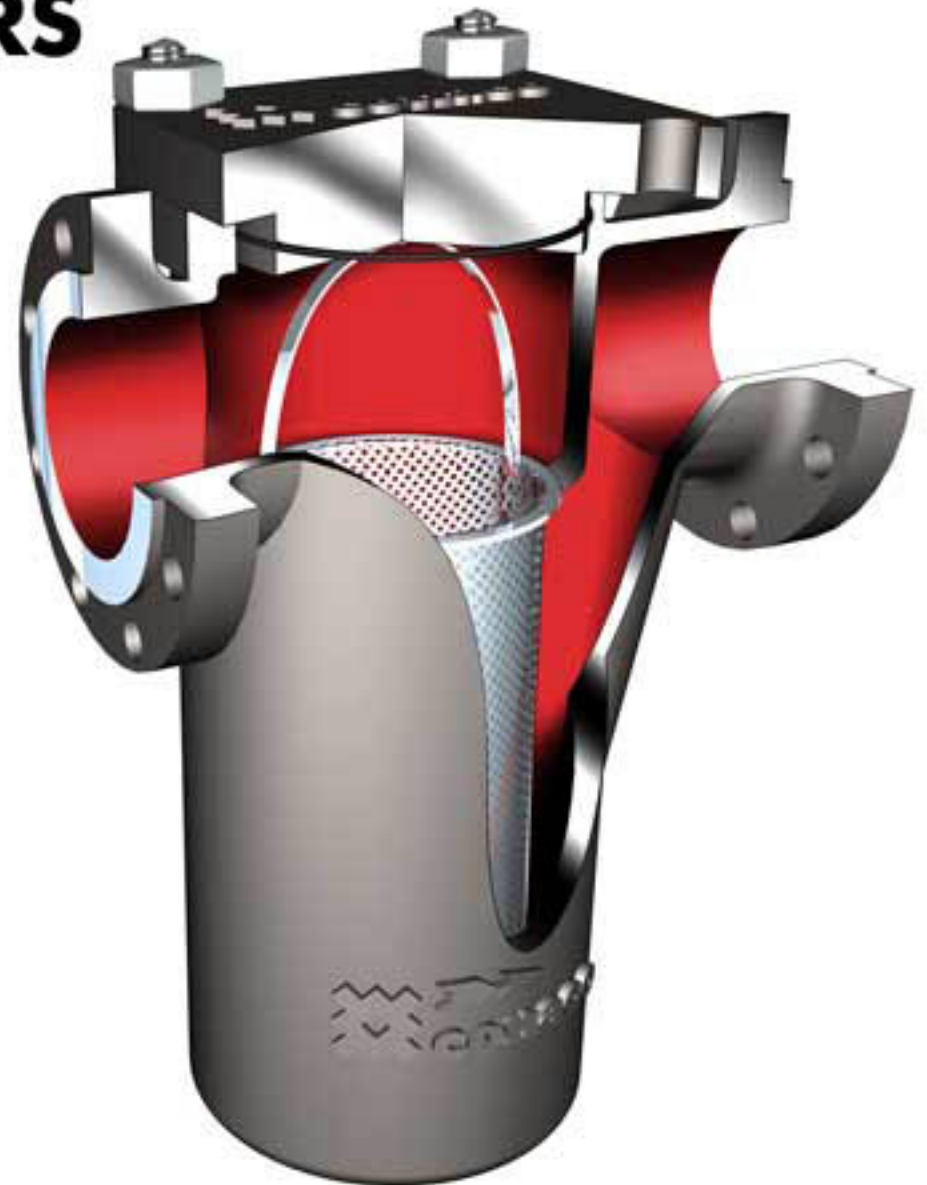

## Parts List and Standard Materials

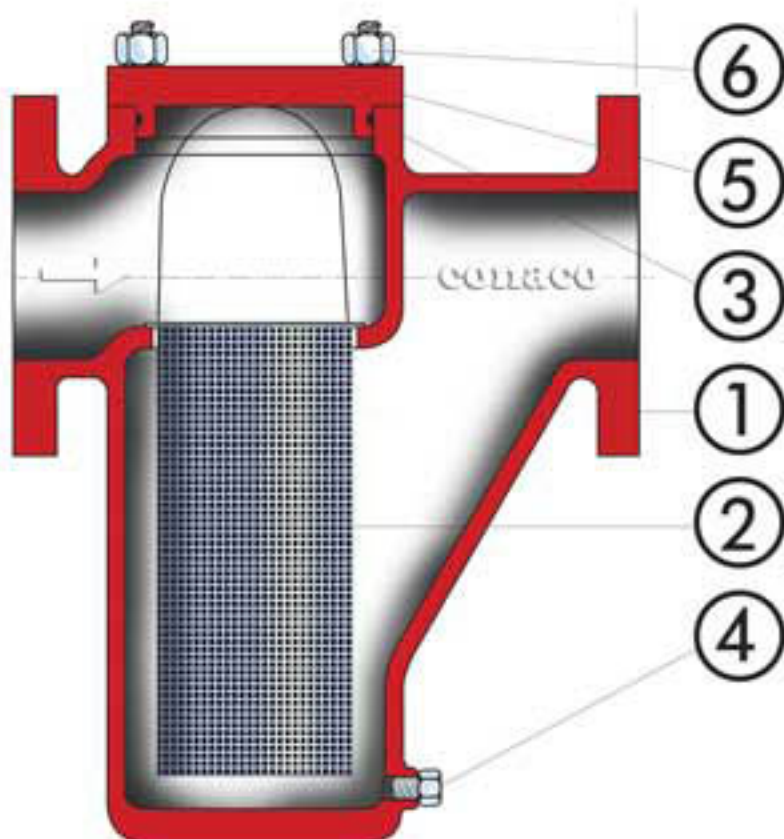

Other materials available.

① Body	② Screen	③ Gasket
ASTM A216 WCB ASTM A216 WCC ASTM A352 LCB ASTM A352 LCC ASTM A217 WC1 ASTM A217 WC6 ASTM A217 WC9 ASTM A217 C5 ASTM A217 C12 ASTM A351 CF3 ASTM A351 CF8 ASTM A351 CF3M ASTM A351 CF8M UNS S31803 UNS S32760 UNS S31254 ALUMINIUM BRONZE	AISI 304 AISI 316 AISI 316L DUPLEX STEEL 6MO MONEL HASTELLOY INCONEL	VITON NITRILE RUBBER
④ Plug	⑤ Cover	⑥ Bolting
ASTM A105 ASTM A350 LF2 ASTM A182 F1 ASTM A182 F5 ASTM A182 F9 ASTM A182 F11 ASTM A182 F22 ASTM A182 F304 ASTM A182 F304L ASTM A182 F316 ASTM A182 F316L ASTM A182 F51 ASTM A182 F44 ALUMINIUM BRONZE	ASTM A105 ASTM A350 LF2 ASTM A182 F1 ASTM A182 F5 ASTM A182 F9 ASTM A182 F11 ASTM A182 F22 ASTM A182 F304 ASTM A182 F304L ASTM A182 F316 ASTM A182 F316L ASTM A182 F51 ASTM A182 F44 ALUMINIUM BRONZE	ASTM A193 B7-A194 2H ASTM A320 L7-A194 Gr.4 ASTM A193 B8-A194 Gr.8

SIZE	Class 150 lb					Class 300 lb				
	A	B	C	D	Kg	A	B	C	D	Kg
2"	290	207	110	350	35	309	207	110	350	35
3"	350	265	140	440	48	350	265	140	440	48
4"	420	350	160	580	62	420	350	160	580	62
6"	550	500	182	800	170	550	500	182	800	180
8"	700	650	244	1000	300	725	650	260	1020	320
10"	850	850	315	1380	420	850	850	325	1400	420
12"	950	950	350	1500	540					
14"	1150	1245	395	1810	930					

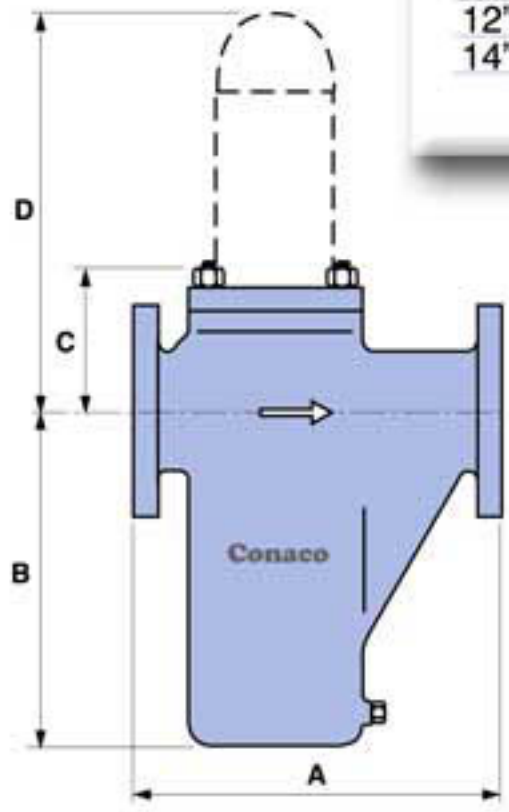

- Dimensions and weights are approximate.
- Standard blow off plug 3/4" NPT.
- Standard filtering element: 40 mesh wire screen on perforated plate support.
- Flanged ends to ANSI B16.5.
- Cover flange to manufacturer's standard.

**Optional Special Features**

- SCREEN: Double or triple layers (mesh on perf. plate, mesh on mesh), magnetic assemblies
- DRAIN: Any combination of nipples, flanges, valves and plugs
- VENT: Optional connection
- DP GAUGE: Optional connections
- LINING: Epoxy
- COATING: Any painting cycle

**Installation**

- Strainers should be installed as close as possible to the machinery or valve to be protected. The arrow cast on the strainer body must point to the direction of the flow.
- For installation on horizontal or inclined pipelines, the screen housing must be below the pipeline.
- Do not install a Basket type strainer on vertical pipelines. Refer to the figures below.

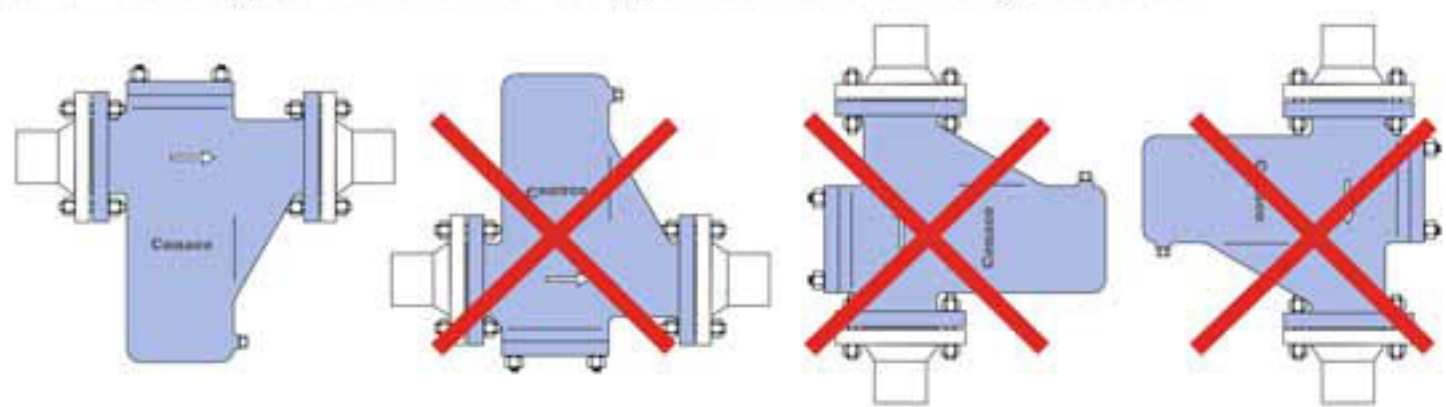

**How To Order**

Always specify: type - rating - end connections - size - body/screen material - filtering degree - drain type  
**Example: No 1 Type 507.1 - #150RF - 10" - WCB/304 - 1.5mm perf - 3/4" NPT Plug**  
 Ask our technical department for the correct sizing with the lowest pressure drop for your application.

**Other Conaco Strainers**

Product	Data Sheet
150 to 2500 lb 1/2" to 1.1/2" type 777 'Y' Strainers	700.9710
150, 300, 600 lb, flanged cover, type 707 'Y' Strainers	701.9710
900, 1500, 2500 lb flanged cover, type 707 'Y' Strainers	702.9710
1500 & 2500 lb, pressure seal, type 707 'Y' Strainers	703.9710
800 lb forged type 767 'Y' Strainers	704.9710
Type 407 'Tee' Strainers	407.9710
Type 444 'Top Hat' Strainers	444.9710

**conaco**  
 a division of **Inoxfucine s.p.a.**

**Via V. Monti, 81**  
**20145 Milano (Italy)**  
**Tel: +39 0248 15055**  
**Fax: +39 0248 16670**  
**e-mail: sales@conaco.it**  
**www.conaco.it**

507-0504